

# AWASH WITH STORAGE IDEAS.



## BATHROOM UNIT



The 'A user's guide to Contiboard' leaflet will help you achieve a professional finish. Filled with tips and hints on how to work with Contiboard we recommend this is read before starting your project. All drilling that goes through the board should be started from the visible side.

1. After drilling all the panels, assemble the unit on its back fit three panels B (ensuring that the panel with the through drilling is fitted in the middle) to panel D. Then fit panel G to the tops of panels B.
2. Fit two panels E to panel A then fit panel A to panel G.
3. Fit the second panel D to the tops of panels E.
4. Fit legs if required.
5. Position and fit the unit to the wall.
6. Insert the shelves.

**Boards required:** 6 x 2m x 250mm x 18mm, 1 x 2m x 350mm x 18mm.

**Fixings required:** 20 x 50mm chipboard screws, 34 shelf supports, 6 x legs - available from B&Q.

## CUTTING AND DRILLING PLANS

Finished size of the bathroom unit when using supplied plans is 2000 x 1600 mm (LxH), plus 150 x 290mm if legs used. Some help will be needed to move the finished unit into position. To convert mm to inches divide the metric measurement in millimetres by 25.4.

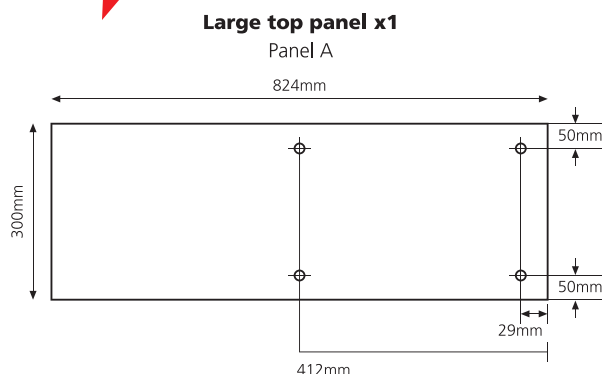

# CUTTING AND DRILLING PLANS

continued...

## Lower unit sides x3

Panel B

Drill 18 holes using a 5mm diameter drill bit to a depth of 13mm (A) on 2 panels, and drill completely through on third.

Drill 4 holes using a 3mm diameter bit to a depth of 13mm (B).

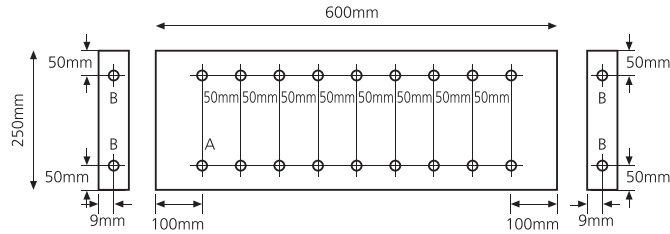

## Lower unit shelves

Panel C

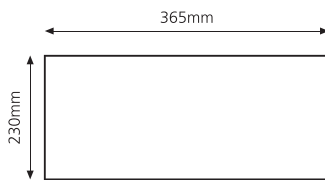

## Main base and top panel x1

Panel D

Drill 4 holes using a 4mm diameter drill bit through the panel.

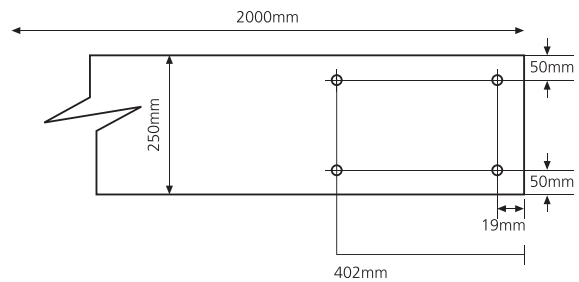

## Upper unit side panels x2

Panel E

Drill 4 holes using a 3mm diameter drill bit to a depth of 30mm (A).

Drill 18 holes using a 5mm diameter bit to a depth of 13mm (B).

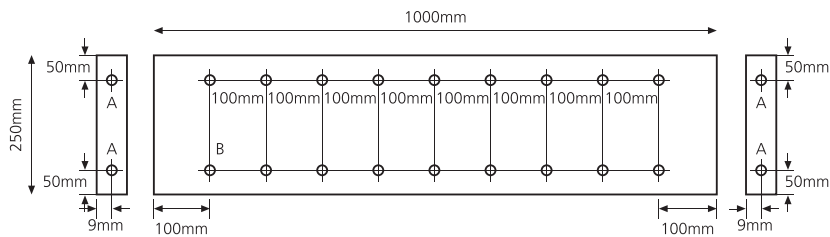

## Upper unit shelves x4

Panel F



## Top panel of lower unit x1

Panel G

Drill 10 holes using a 4mm diameter bit through panel (A).

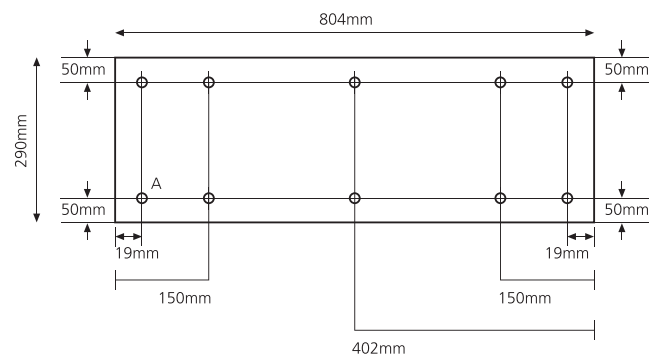

# THE VERSATILE CONTIBOARD RANGE

## A FINISH FOR EVERY SITUATION

Whether you live in a modern or traditional home, storage units can make or break a room. That's why we've designed a range of boards with a high-spec melamine finish that can be made to not only fit the shape of your home, but also the style. And because interior design is constantly changing, we're always developing and broadening our range of different coloured and printed designs. **All you need to do is add imagination.**

### TOOLS REQUIRED

- Square, measuring tape and pencil
- Electric power saw with correct blade or hand saw (14 teeth per 25mm)
- Screwdrivers, screws, sharp marking/trimming knife
- Electric iron, glasspaper and block
- Drill with drill bits suitable for wood
  - Drill with 3mm and 5mm drill bits

### SIZES AVAILABLE

Finish	White Melamine		Finish effects*
	15mm	15mm	
Thickness	15mm	15mm	18mm
Sizes	152 x 1830mm 229 x 1830mm 305 x 1830mm 381 x 1830mm 533 x 1830mm 610 x 1830mm	152 x 2440mm 229 x 2440mm 305 x 2440mm 381 x 2440mm 533 x 2440mm 610 x 2440mm 762 x 2440mm 1220 x 2440mm	150 x 2000mm 250 x 2000mm 325 x 2000mm 450 x 2000mm 600 x 2000mm

#### \*Finish effects include:

Cherry Modern effect; Rift Beech effect; Traditional Oak effect; Cream effect; Walnut effect; Chocolate Oak effect; Maple effect and Oak effect.

The manufacturer reserves the right to withdraw or alter range or part range. Matching ContiStrip iron on edging is available to finish sawn edges.

#### Caution and Safety

- Care should be taken when working with all timber products and the correct protective equipment used.
- Do not overtighten fixing screws.
- Ensure that you have sufficient working space to construct the unit.
- Heavy units are difficult to move and may require help from an additional person.
- Keep all tools and fixing items out of reach of children to prevent accidents occurring.
- Screw cap covers can easily choke a child. Glue these into place for extra safety.
- Check for wires and pipes with a special battery-powered detector before drilling.
- Always restrain freestanding units if there is a possibility of children climbing on them. Cleaning melamine or foil faced particleboard.
- Use mild soap and water only on a slightly damp cloth.
- Do not use abrasive or solvent cleaners.

ContiBoard has been offering an alternative to ill-fitting, mass-produced, flat-packed furniture for over 25 years. The versatile nature and wide range of appealing finishes of our boards means that during that time they have been made into wardrobes, cupboards, shelving, storage boxes, tables... whatever you could think of really: Some weird, all wonderful.

**We look forward to seeing what ideas you come up with in the next 25 years.**



**JUST ADD IMAGINATION**

**CONTI DIY PRODUCTS  
NORBORD LTD  
SOUTH MOLTON  
DEVON EX36 4HP  
TEL. 01769 575400**

